

NSHCH-15.19.100-OS 2217-1T-25

Primary Usage

Reference No.

Sign. and date

Copy inv. No.

Repl. Inv. No.

Sign. and date

Orig. Inv. No.

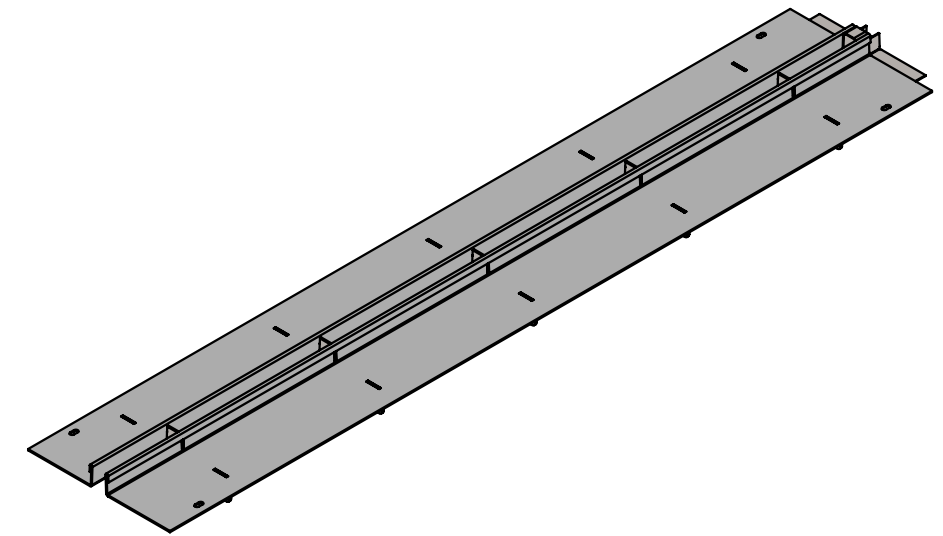
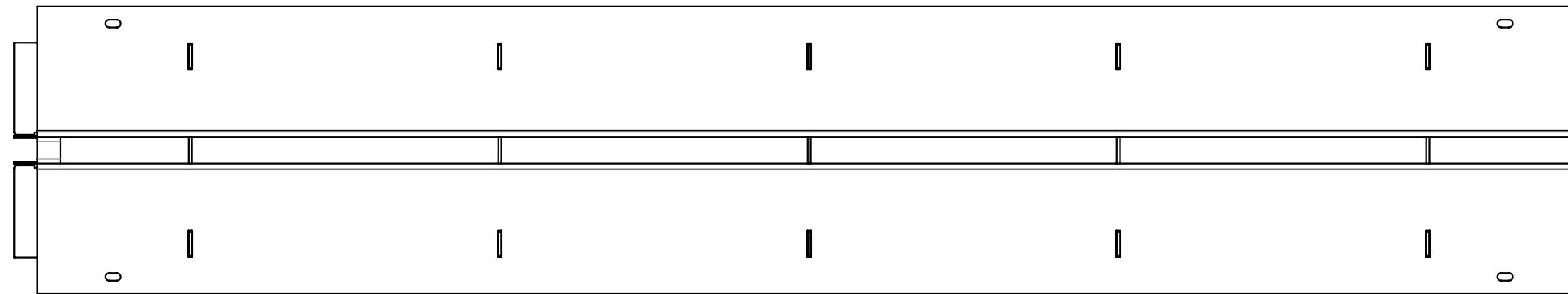
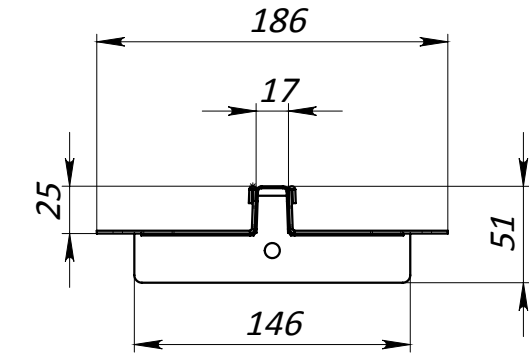
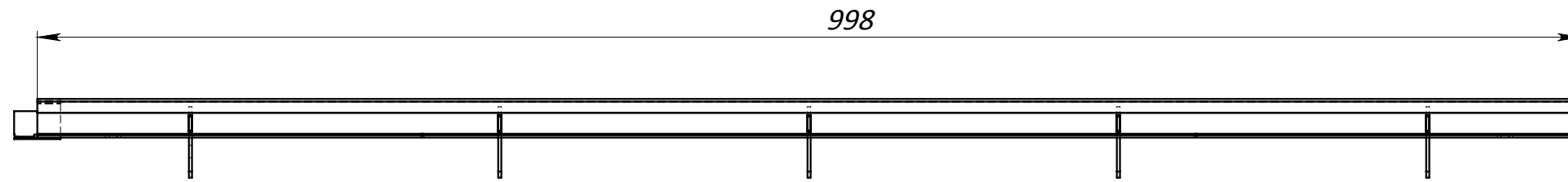

- 1. Area of water intake slots 170 sq cm
- 2. Deviation of the actual weight of the nominal can be up to 10%

					Art. 2217-1T-25				
					NSHCH-15.19.100-OS 2217-1T-25				
					Galvanized Steel Micro Slot Drain		Let.	Weight	Scale
								3.06	1:4
							Sheet	Sheets 1	
					Galvanized Steel		