

NSHCH-20.24.100-OS 2517-1TT-100

Primary Usage

Reference No.

Sign. and date

Copy inv. No.

Repl. Inv. No.

Sign. and date

Orig. Inv. No.

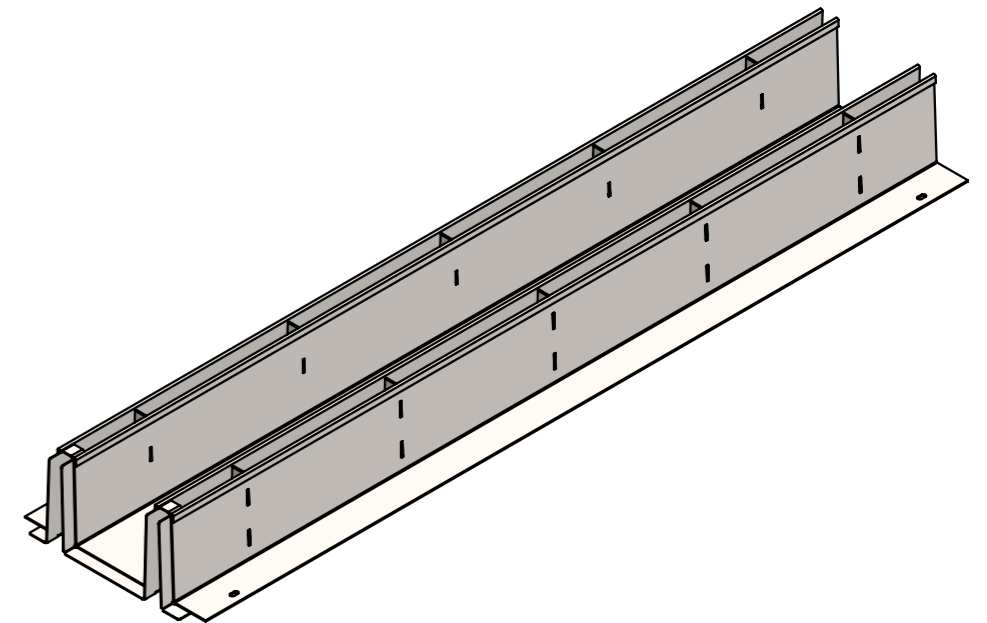
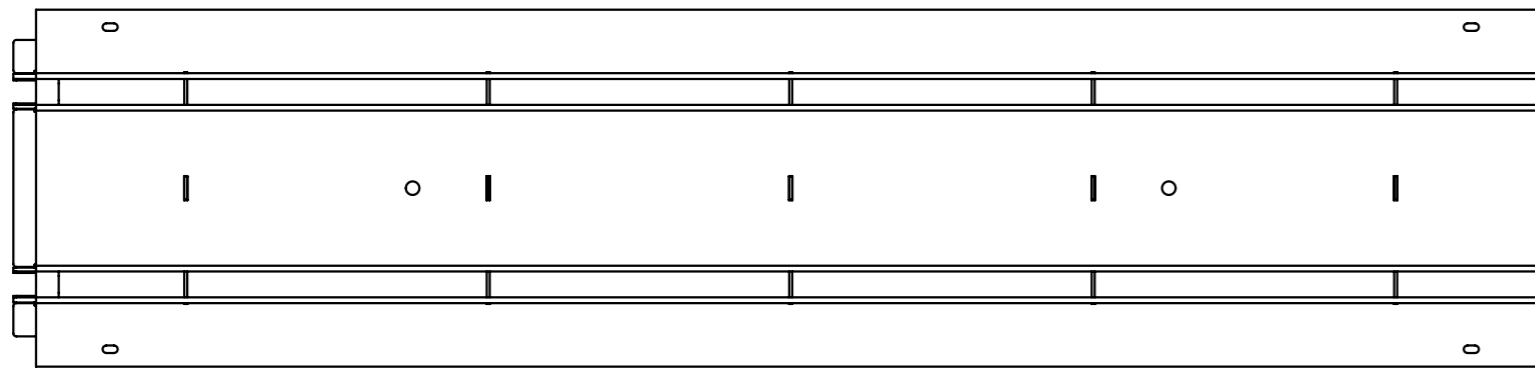
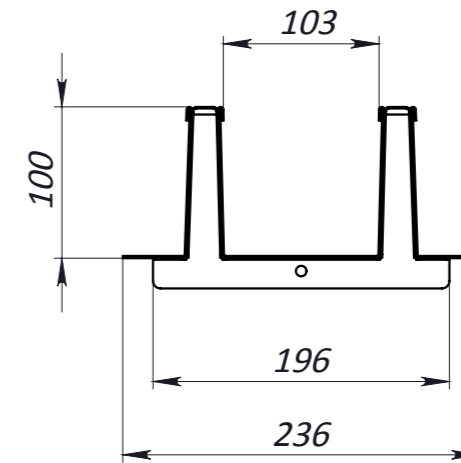
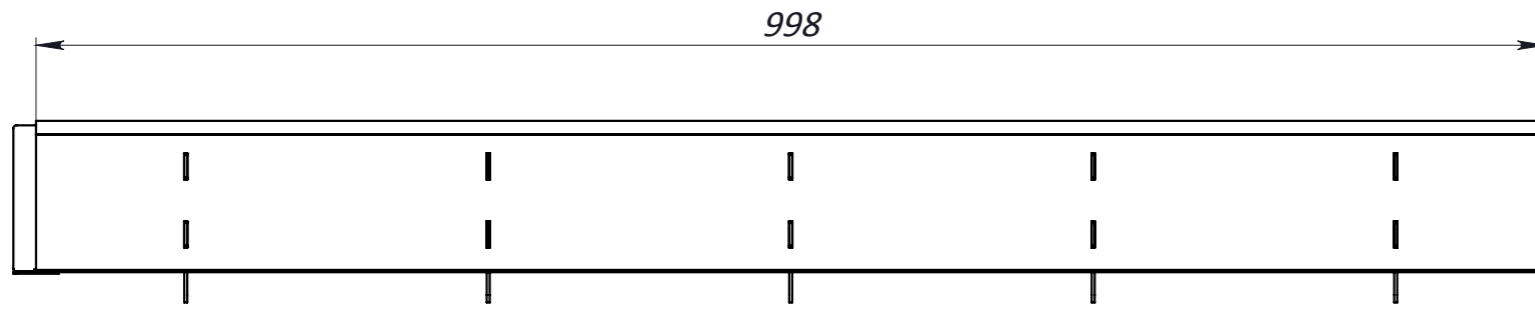

- 1. Area of water intake slots 340 sq cm
- 2. Deviation of the actual weight of the nominal can be up to 10%

					Art. 2517-1TT-100				
					NSHCH-20.24.100-OS 2517-1TT-100				
					Galvanized Steel Double Slot Drain		Let.	Weight	Scale
Rev.	Sheet	Doc. No.	Sign.	Data				8.12	1:5
							Sheet	Sheets 1	
					Galvanized Steel		