

NSHCH-20.24.100-OS 2517-1T-100

Primary Usage

Reference No.

Sign. and date

Copy inv. No.

Repl. Inv. No.

Sign. and date

Orig. Inv. No.

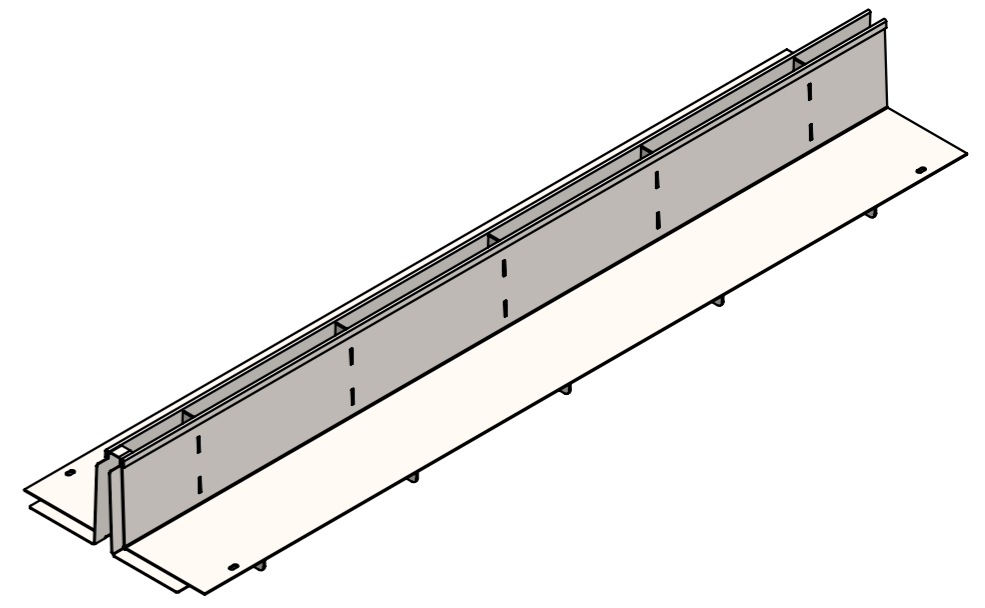
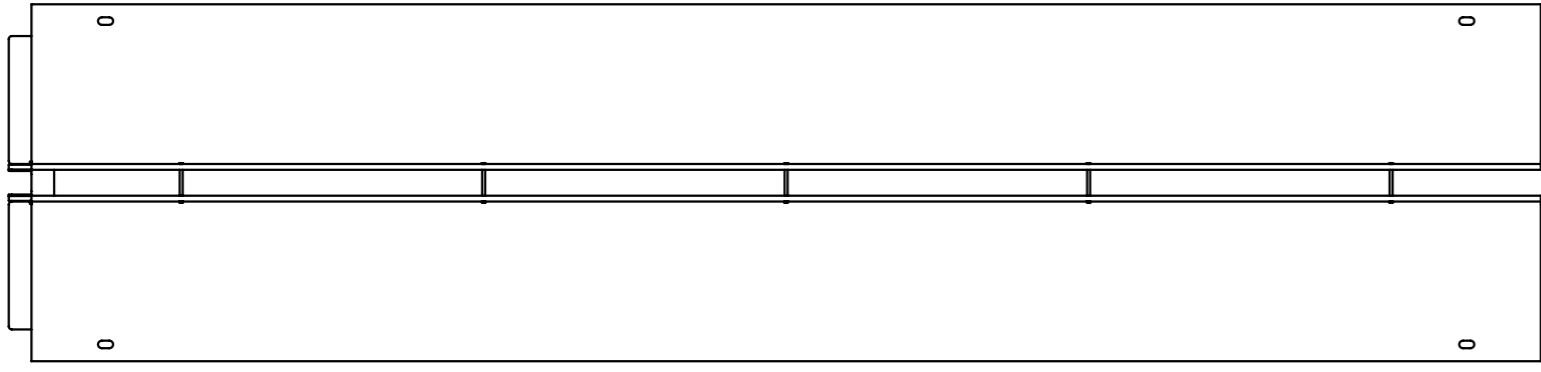
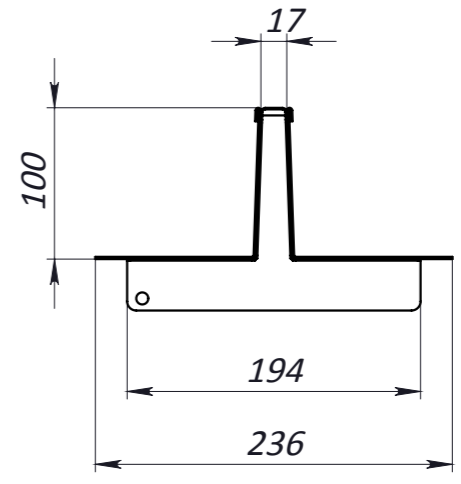
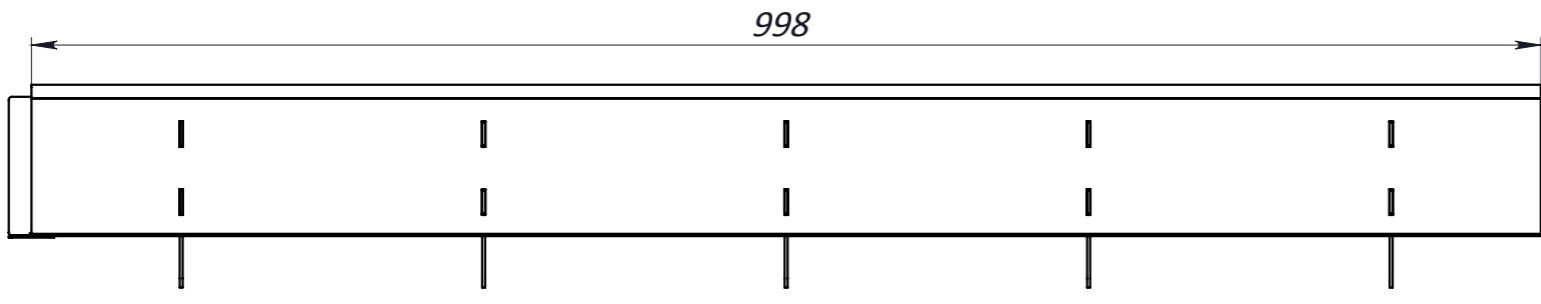

- 1. Area of water intake slots 170 sq cm
- 2. Deviation of the actual weight of the nominal can be up to 10%

					Art. 2517-1T-100			
					NSHCH-20.24.100-OS 2517-1T-100			
Rev.	Sheet	Doc. No.	Sign.	Data	Galvanized Steel Slot Drain	Let.	Weight	Scale
				25.07.18			5.73	1:5
					Galvanized Steel		Sheet 1	
					Galvanized Steel		