

Primary Usage	
Reference No.	
Sign. and date	
Copy inv. No.	
Repl. Inv. No.	
Sign. and date	
Orig. Inv. No.	

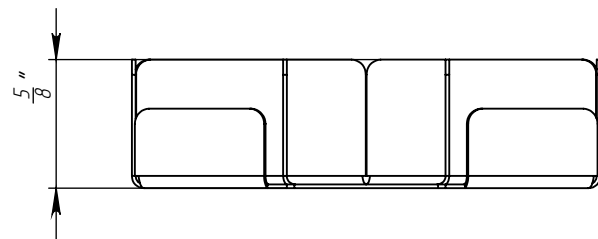
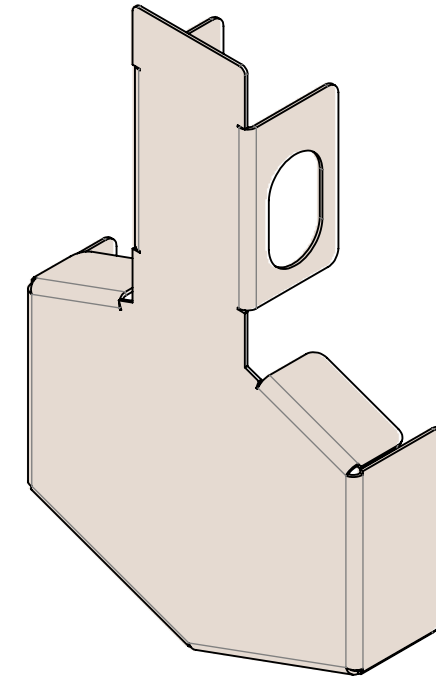
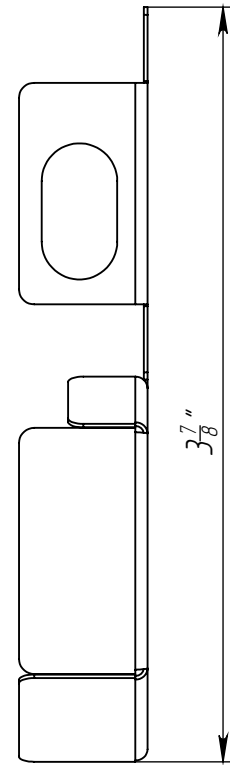
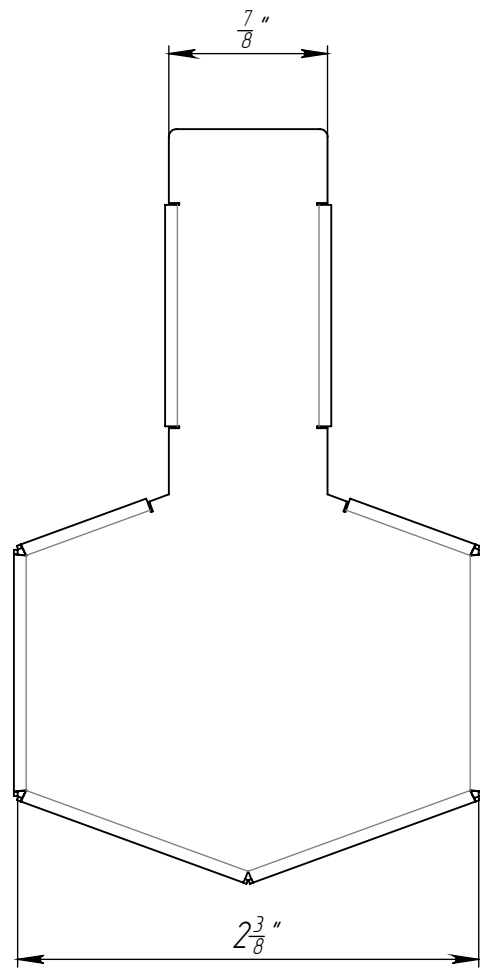

- \* - Dimensions for reference;
- Unspecified marginal deviation of dimensions H14, h14, +IT14/2;
- General tolerances of form and placement - GOST 30893.2;
- Delivery and packaging are carried out in accordance with the terms of the contract
- The manufacturer reserves the right, without notice to the consumer, to make changes to the design of the products for improvement their technological and operational parameters, which will not affect the quality and properties of the product.

Quantity, pcs. \_\_\_\_\_ Agreed with the customer \_\_\_\_\_ Date \_\_\_\_\_

					Art.	SSSDV40		
					<b>Mini Slot End Caps</b>			
						Let.	Weight (lb)	Scale
							0.06	1:1
					Sheet	Sheets 1		
					<b>Stainless Steel</b>			